

# MD-X SERIES

## MD-X Specifications

Item		Unit	MD55X				MD85X				MD110X				
CLAMPING UNIT	Clamping System	—	Double Toggle				Double Toggle				Double Toggle				
	Clamping Force	USt	56				84				112				
	Location Hole Diameter	inch	4				4				4				
	Distance Between Tie Bars (HXV)	inch	12.60×12.60				14.17×14.17				16.14×16.14				
	Platen Size (HXV)	inch	18.50×18.50				20.87×20.87				24.02×24.02				
	Mold Opening Stroke	inch	9.84				11.81				13.78				
	Mold Height (min./max.)	inch	6.30/14.57				6.69/16.14				7.87/17.72				
	Open Daylight	inch	24.41				27.95				31.50				
	Ejector Stroke	inch	2.76				3.15				3.94				
	Ejector Force	Ust	2.2				2.8				3.4				
INJECTION UNIT	Injection Capacity *1	T·m	i 0.7	i 1.0			i 1.7			i 2.7					
	Screw Complete	Type	—	Y (op.)	YA	A	B	Y (op.)	YA	A	B	Y (op.)	YA	A	B
		Diameter	inch	0.71	0.87	0.98	1.18	0.98	1.10	1.18	1.38	1.18	1.26	1.38	1.57
	Screw Stroke	inch	3.35	3.94			4.72			5.51					
	Calculated Injection Volume *2	cu.in	1.34	2.32	2.99	4.33	3.60	4.52	5.19	7.02	6.04	6.90	8.24	10.74	
	Injection Weight (PS) *3	oz	0.71	1.23	1.59	2.29	1.90	2.40	2.75	3.74	3.21	3.67	4.37	5.71	
	Max. Injection Pressure *4	PSI	40610	36260	29010	20310	40610	33360	29010	21760	39160	34810	29010	22480	
	Max. Holding Pressure *4	PSI	40610	33360	26110	18130	37710	30460	26110	19580	35530	31180	26110	19580	
	Holding Pressure Hold Time *4	PSI×s	37710 ×60	25240 ×60	19580 ×60	13630 ×60	28140 ×85	22480 ×85	19580 ×85	14360 ×85	26690 ×100	23350 ×100	19580 ×100	14940 ×100	
	Max. Injection Speed *5	inch/s	9.84				9.84				10.24				
	Injection Rate	cu/in/s	3.91	5.80	7.51	10.80	7.51	9.40	10.80	14.71	11.22	12.75	15.26	19.95	
	Screw Speed	min <sup>-1</sup>	360				360				360				
	Plasticizing Capacity (PS) *6	oz/s	0.09	0.18	0.26	0.42	0.26	0.35	0.42	0.59	0.42	0.50	0.59	0.86	
	Nozzle Stroke	inch	11.42				13.39				14.57				
	Nozzle Touch Force	USt	2.02				2.42				3.26				
	Number of Temperature Control Zone	Nozzle/Heating Barrel	—	1G+2+1G				1G+2+1G				1G+2+1G			
		Hopper Base	—	1				1				1			
Heating Capacity	kW	2.94	3.44	4.17		5.06	6.31			6.91	8.11				
OTHERS	Electric Capacity *7	kVA	17				21				35				
	Power Supply	—	AC200V (±10%) ×50Hz												
			AC200/220V (±10%) ×60Hz												
	Machine Weight	Ust	2.6				3.8				4.7				
	Hopper Capacity (Option)	gal	3.96				3.96				11.89				
	Amount Cooling Water (Max.) *8	L/min	5				5				5				
Machine Size (L×W×H)	inch	121.5×43.15×62.40				142.8×44.76×67.40				158.7×45.55×69.96					

Notes: • Specifications are subject to change without notice.

- \* 1. Injection capacity = (Injection pressure) × (Theoretical shot volume)
- \* 2. Theoretical shot volume = (Screw cross section) × (Screw stroke)
- \* 3. The shot mass (PS) is assumed to be 92% of theoretical shot volume.
- \* 4. Max. injection pressure and max. holding pressure may be limited by cycle time.
- \* 5. The maximum injection speed may not reach this value, depending on the status of load.
- \* 6. Plasticizing capacity is assumed by polystyrene.
- \* 7. Shows the capacity of machine: When branching the power supply of auxiliary device from molding machine, increase the capacity by that value.
- \* 8. Used to cool the hopper base: Set the water pressure to less than 72.5 PSI.

# MD85X

## External Dimension Diagram

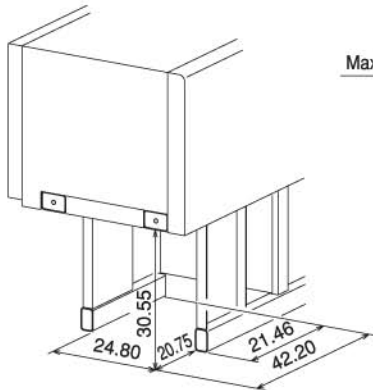
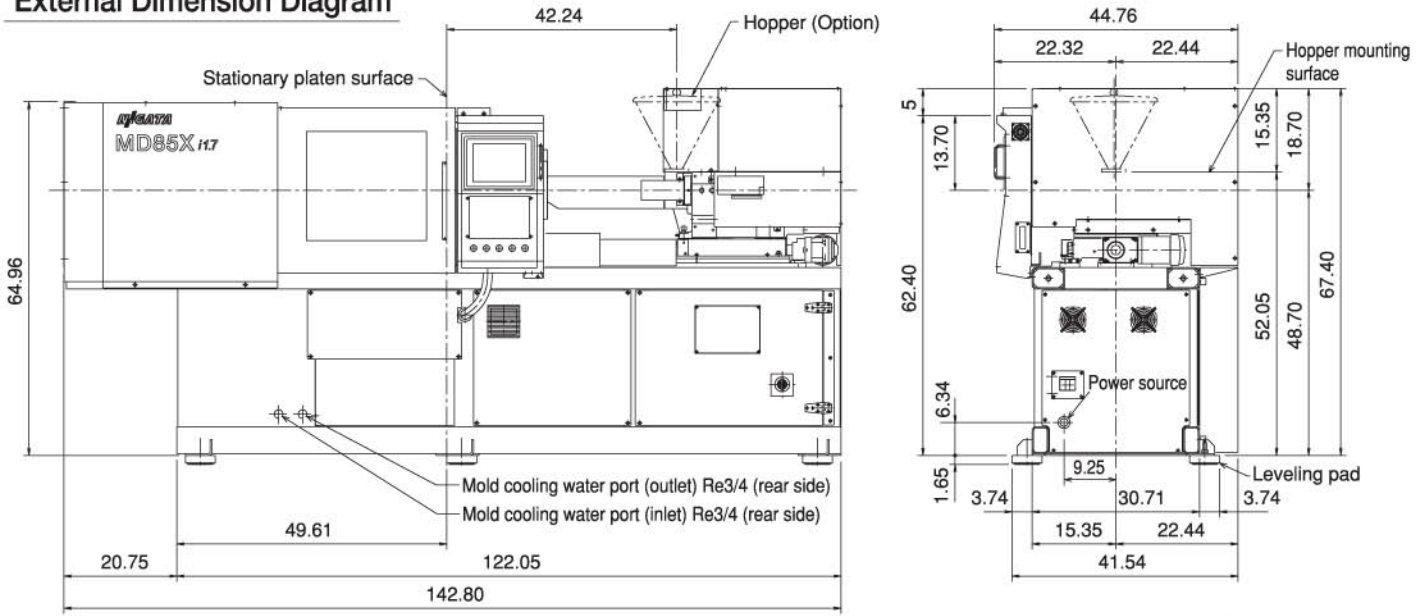

## Products Drop Area

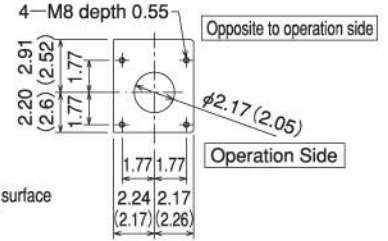
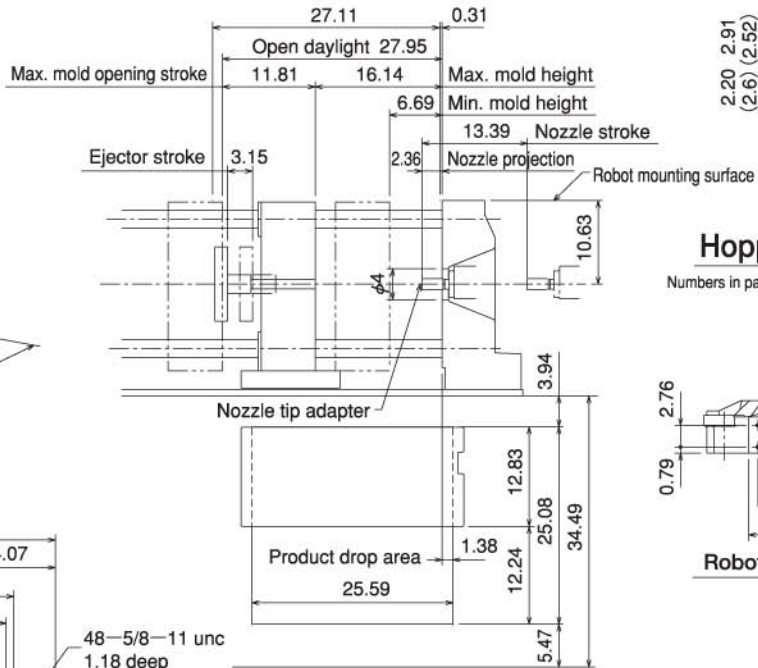

## Hopper Base Dimension

Numbers in parentheses ( ) are for screw with  $\phi 0.98$  diameter.

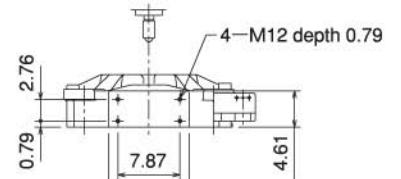

## Robot mounting hole

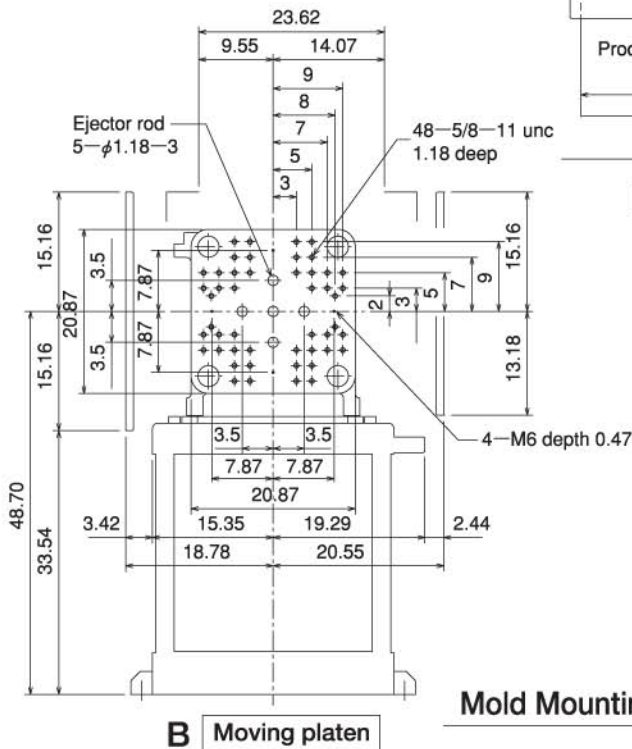

B ← → A

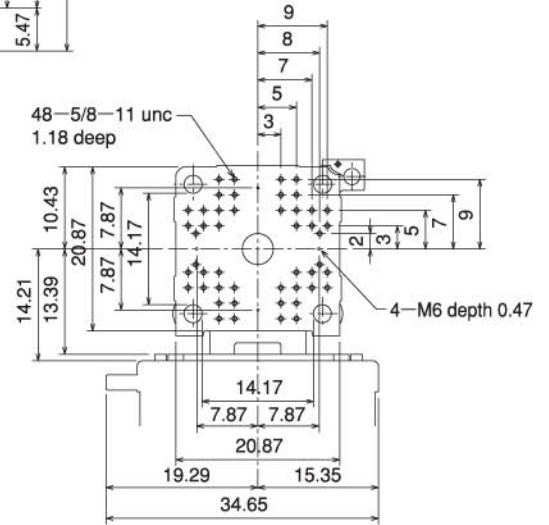

## Mold Mounting Dimensional Diagram